

Samuel Bradshaw, 1st Period – Math Project – Lesson 11.3

Write: 11.3 Notes

The Area of a Trapezoid

Draw:



Ask: **“Does anyone know how to find the area of a trapezoid?”**
(they should say something like “you draw lines to divide it into 2 triangles and a rectangle. Then you find the area of each part.” Or “ $b_1 + b_2 \times h / 2$ ”)

Theorem: “Area of trapezoid = $\frac{\text{height}(\text{base}_1 + \text{base}_2)}{2}$ ”

Ask: **“Okay, where are the bases?”**
(“the top line and the bottom line”)

Show:



Draw:

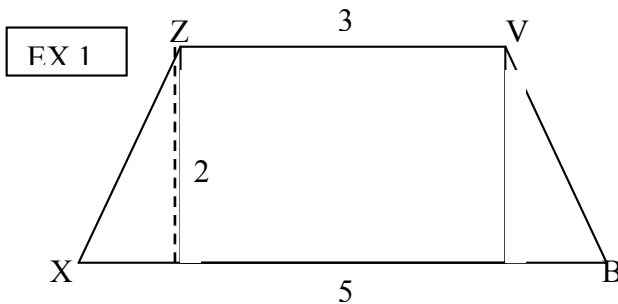

Write: “Given: Trapezoid ZVBX, with height 2,
lower base 5, and upper base 3”

“Find: The area of ZVBX”

Ask: **“What’s the area?”**
(“8 units²”)

Show: “ $A = \frac{2(5+3)}{2}$ ”

$$“A = \frac{2(8)}{2} = \frac{16}{2} = 8”$$

(Erase overhead and continue...)

Draw:

FX 2

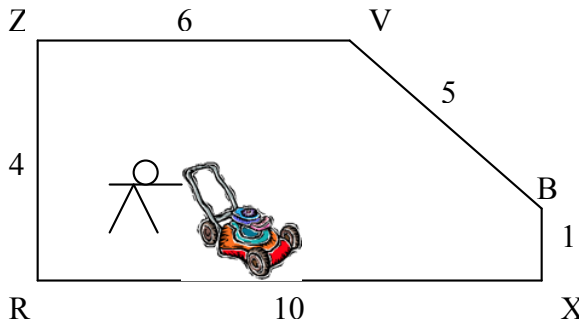

Write: "Little Johnny was asked to mow his lawn. His dad will pay him for each square foot. How many square feet are there in his yard? All angles that look right are. Dimensions are in feet."

Ask: "What's the area of his yard?"

("8 units²")

Show: "A_{TRAP} = $\frac{3(10+6)}{2}$ "

"... = $\frac{3(16)}{2} = \frac{48}{2} = 24$ "

"A_{RECT} = 1(10) = 10"

"A_{RECT} + A_{TRAP} = 34"

"34 ft²"

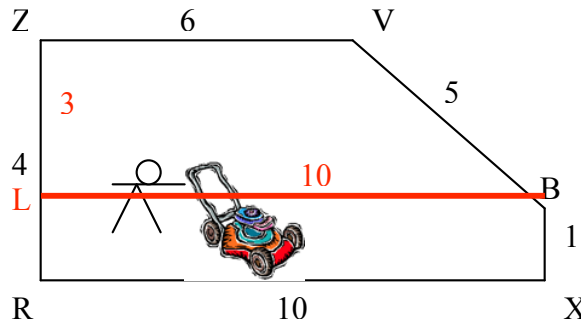

The Median of a Trapezoid

Draw:



Ask: "What's a median in a trapezoid?"

Write: "A median is a line segment joining the midpoints of the non-parallel sides of the trapezoid."

Show:

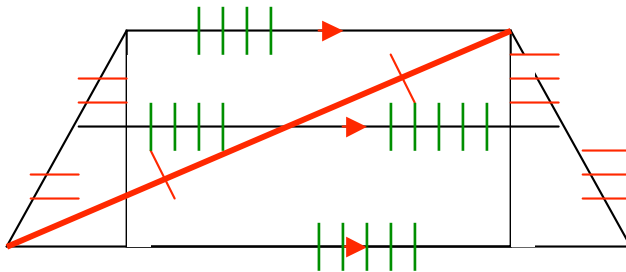

The green markers show the midline theorem (triangles) – midline is half of base (NOT congruency markers)

Theorem: "The measure of the median of a trapezoid equals the average of the measures of the bases."

$$M = \frac{1}{2}(b_1 + b_2)$$

Theorem: "Area of a trapezoid = median X height"

(Erase overhead and continue...)

EX 3

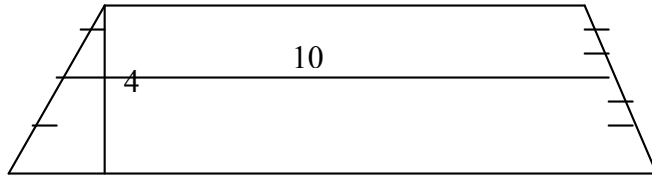

Ask: *“What’s the area?”*

Homework for today:

Pg. 525 #1-4, 6, 7

(Erase overhead and continue...)